



PT9926

20V N-Channel Enhancement Mode MOSFET

VDS= 20V

RDS(ON), Vgs@2.5V, Ids@5.2A <40mΩ

RDS(ON), Vgs@4.5V, Ids@6A < 30mΩ

Features

- Advanced trench process technology
- High Density Cell Design For Ultra Low On-Resistance
- High Power and Current handling capability
- Ideal for Li ion battery pack applications

Package Dimensions

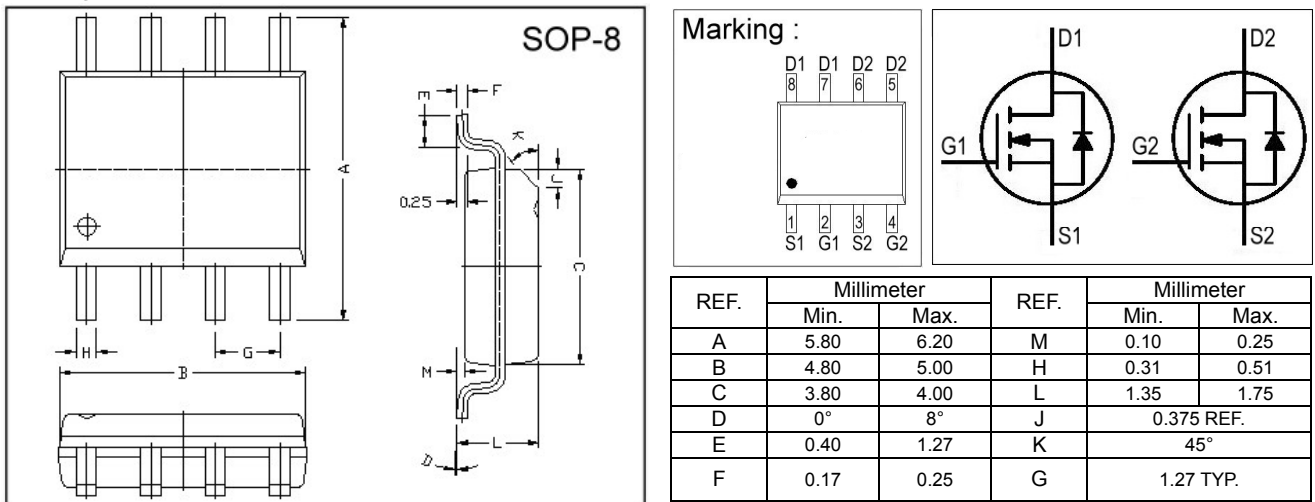

Maximum Ratings and Thermal Characteristics (TA = 25°C unless otherwise noted)

Parameter	Symbol	Limit	Unit	
Drain-Source Voltage	V _{DS}	20	V	
Gate-Source Voltage	V _{GS}	± 12		
Continuous Drain Current	I _D	6	A	
Pulsed Drain Current ¹⁾	I _{DM}	20		
Maximum Power Dissipation	P _D	TA = 25°C	2	W
		TA = 75°C	1.28	
Operating Junction and Storage Temperature Range	T _J , T _{stg}	-55 to 150	°C	
Junction-to-Ambient Thermal Resistance (PCB mounted) ²⁾	R _{θJA}	62.5	°C/W	

Notes

- Pulse width limited by maximum junction temperature.
- Surface Mounted on FR4 Board, t ≤ 5 sec.



ELECTRICAL CHARACTERISTICS

Parameter	Symbol	Test Condition	Min.	Typ.	Max.	Unit
Static						
Drain-Source Breakdown Voltage	BV_{DSS}	$V_{GS} = 0V, I_D = 250\mu A$	20	-	-	V
Drain-Source On-State Resistance	$R_{DS(on)}$	$V_{GS} = 2.5V, I_D = 5.2A$		32.0	40.0	m Ω
Drain-Source On-State Resistance	$R_{DS(on)}$	$V_{GS} = 4.5V, I_D = 6A$		23.0	30.0	
Gate Threshold Voltage	$V_{GS(th)}$	$V_{DS} = V_{GS}, I_D = 250\mu A$	0.5		1.2	V
Zero Gate Voltage Drain Current 0	I_{DSS}	$V_{DS} = 20V, V_{GS} = 0V$			1	μA
Gate Body Leakage	I_{GSS}	$V_{GS} = \pm 10V, V_{DS} = 0V$			± 100	nA
Forward Transconductance	g_{fs}	$V_{DS} = 10V, I_D = 6A$		5	—	S
Dynamic						
Total Gate Charge	Q_g	$V_{DS} = 10V, I_D = 6A$ $V_{GS} = 4.5V$		5	7	nC
Gate-Source Charge	Q_{gs}			1		
Gate-Drain Charge	Q_{gd}			1.5		
Turn-On Delay Time	$t_{d(on)}$	$V_{DD} = 10V, R_G = 6\Omega$ $I_D = 1A, V_{GS} = 4.5V$		8	20	ns
Turn-On Rise Time	t_r			10	20	
Turn-Off Delay Time	$t_{d(off)}$			22	45	
Turn-Off Fall Time	t_f			6	15	
Input Capacitance	C_{iss}	$V_{DS} = 8V, V_{GS} = 0V$ $f = 1.0\text{ MHz}$		565		pF
Output Capacitance	C_{oss}			105		
Reverse Transfer Capacitance	C_{rss}			75		
Source-Drain Diode						
Max. Diode Forward Current	I_S				1.7	A
Diode Forward Voltage	V_{SD}	$I_S = 1.7A, V_{GS} = 0V$			1.2	V

Note:Pulse test: pulse width $\leq 300\mu s$, duty cycle $\leq 2\%$

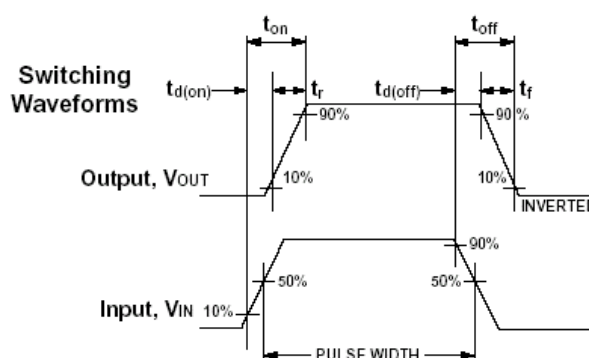
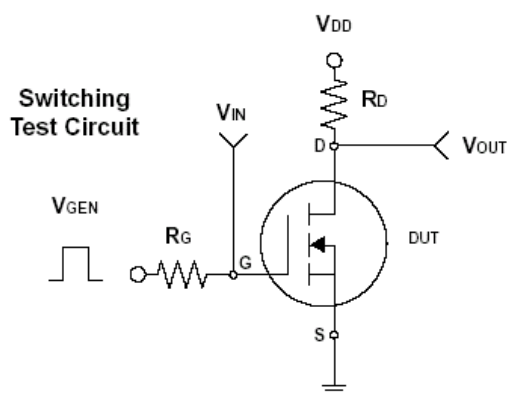

Typical Characteristics (T_J = 25°C Noted)

